



390 SERIES HIGH CAPACITY SHREDDERS

**20390
20394
20396**

Dahle North America, Inc.

375 Jaffrey Road
Peterborough, NH 03458
Tel: (603) 924-0003 • Fax: (603) 924-1616
Email: shredders@dahle.com
w w w . d a h l e . c o m

OPERATION MANUAL

20390.90.1830 – 01/04 –

For More Info

Click Here --->



Congratulations on your purchase of a DAHLE High Capacity Shredder! We here at DAHLE North America are dedicated to providing rugged and dependable products for the large, and not so large office. We are sure your new DAHLE High Capacity Shredder will meet or exceed your expectations of quality and service.

If you have any questions regarding your new DAHLE paper shredder, call your sales representative, or call DAHLE N.A. Customer Service, toll free, at (800) 995-1379 between 8:30 am and 5:00 pm Monday through Friday, EST.

Check off the model and record the serial number for your records in the space provided below.

- 20390 20394 20396

Serial Number: _____

DIAGRAM KEY

- 1. Main Plug
- 2. Feed Opening
- 3. Light Barrier
- 4. Bag Full Indicator
- 5. Door Ajar Indicator
- 6. Paper Jam Indicator
- 7. Forward Switch
- 7a. Reverse Switch
- 8. Power Switch
- 9. Waste Bin
- 10. Door Handle
- 11. Door

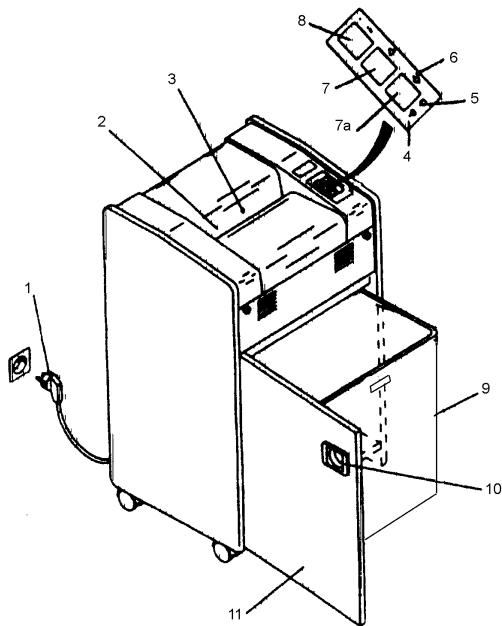

704

DAHLE SHREDDER SUPPLIES AND ACCESSORIES

Shred Bags (100 per box)

805

Item No.	Models
701	Personal & 20300 Series 20400, 20500 & 20600 Series
705	20800 Series
706	High Capacity Models

740G

Waste Bin

800 Series

Shredder Oil (All Models)

740	Box of 4 16oz. Bottles
	Box of 4 1gal Bottles
740G/1	1 gallon bottle

Automatic Oiling System

SAO-120 4 Liter Auto Oiler

For More Info



Click Here ---->

IF ANY OTHER PROBLEMS OCCUR. CALL YOUR AUTHORIZED DAHLE SERVICE DEALER

IF ANY OTHER PROBLEMS OCCUR. CALL YOUR AUTHORIZED DAHLE SERVICE DEALER

DAHLE Shredder Oil is the only lubricant you should use in your paper shredder. It has been specially formulated so as not to leave any residue that could attract dust and clog the shredding mechanism. You can order DAHLE Shredder Oil (item # 740) from your local dealer.

Repairs on your paper shredder should only be performed by qualified technicians. **If you need service**, contact your local dealer, or you can contact DAHLE North America Customer Service between 8:30 am and 5:00 pm EST at (800) 995-1379.

BEFORE YOU CALL FOR SERVICE

SYMPTOM	POSSIBLE CAUSES	SOLUTION
No Power	1. Power button not pressed	Press button (green light turns on)
	2. Unit unplugged	Connect to outlet
	3. Outlet dead	Reset circuit breaker
	4. Door not fully closed	Close Door
	5. Shred Bag full	Change Shred Bag
Low capacity	1. Cutting blades dry	Lubricate cutting blades according to instructions.

SAFETY INSTRUCTIONS



- Read the operating instructions carefully prior to starting up the unit!
- Do not use in the vicinity of inflammable liquids or gases.
- Do not use in the vicinity of corrosion materials.
- Do not expose to the wet.
- Do not let children operate this office equipment.
- Do not reach into the cutting mechanism during operation - not even from the top or with objects.
- Do not use the shredder over a period of more than 5 minutes in no-load operation (operation without paper).
- Keep long hair clear of machine.
- Keep neck-ties clear of machine.
- Keep bracelets clear of machine.
- Power supply must be accessible all the times.
- Disconnect power supply before servicing.
- The safety devices must not be manipulated with or removed.
- Please make sure that the shredder gets sufficient ventilation (ventilating flaps must kept free).

BEFORE YOU SHRED

- Remove Transport Bolts with wrench provided.
- Record the Model and Serial Number in the space provided inside the front cover.
- Be sure the electrical outlet provides the proper power for your shredder (see rating label on rear of shredder).
- Install Shred Bag (see: "CHANGING THE SHRED BAG").

TURNING ON YOUR SHREDDER

1. ON, OFF are controlled by the green push button found on top of the shredder.
2. Press this button turns the shredder on And places it in the stand-by mode.
3. Pressing the button again turns the shredder off.

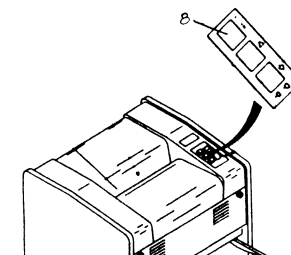

For More Info

Click Here ---->



NOTE: SHREDDER WILL NOT OPERATE UNLESS DOOR IS COMPLETELY CLOSED

ALWAYS TURN SHREDDER OFF IF IT WILL BE UNATTENDED FOR LONG PERIODS OF TIME

SHREDDING

Turn shredder on. Insert paper squarely into Feed Opening (3). A light barrier will automatically activate the shredding mechanism. Continue feeding paper into the Feed Opening until the shredding mechanism begins to draw the paper in. At this point, allow the paper to feed into the shredder on its own. Once the paper has passed completely through the shredding mechanism, the electronic controls will automatically stop the machine.

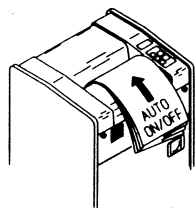

To shred a piece of paper too small to break the light barrier, press the FORWARD button (7) once to override the auto ON/OFF function. The shredder will continue to run until the FORWARD button is pressed again.

Microfiche and transparencies can also be shredded in the same manner as paper, however, you should shred a piece of paper after every 8 or 10 sheets of plastic. This helps clean plastic particles out of the shredding mechanism.

CAPACITY

Capacity is the number of sheets of 8½" x 11" paper that can be shredded at one time. These figures are approximate and machines may vary slightly due to various conditions. It is not recommended that you try to run your shredder at maximum capacity, as this increases the chance of a paper jam.

<u>Model</u>	<u>20 Lb. Bond</u>	<u>16 Lb. Bond</u>
20390	55	60
20394	10	15
20396	38	43

CLEARING A PAPER JAM

If too many sheets of paper are fed into your shredder at one time, it may cause a paper jam. Running your shredder at maximum capacity increases the chance of a paper jam. If a paper jam occurs, it is easy to clear by following these simple steps:

The Auto-Reverse feature, built into the electronic versions of DAHLE High Capacity Shredders, helps prevent paper jams. If the Auto-Reverse feature is activated an audible alarm sounds and the Paper Jam Indicator (6) lights up. If this situation occurs, follow these simple steps:

1. Remove paper from Feed Opening. The REVERSE button (7a) may be used if excess paper remains in the Feed Opening. Clear shredding mechanism by pressing the FORWARD button (7).
2. Separate some of the sheets and continue shredding.

CHANGING THE SHRED BAG

When the Shred Bag is full, the shredder will automatically shut down. On the electronic models an LED indicator will light and an audible alarm will sound. Changing the Shred Bag is quick and easy if you follow these simple directions.

1. Turn shredder off
2. Open Door (11) using Door Handle (10) to expose Waste Bin (9) and Shred Bag.
3. Slide Waste Bin and full Shred Bag from shredder.
4. Dispose of full Shred Bag.
5. Install new Shred Bag in Waste Bin, draping the edge of the Shred Bag over the lip of the Waste Bin.
6. Slide Waste Bin, with new Shred Bag installed, back into shredder.
7. Close Door.
8. Turn on shredder and continue shredding.

CARING FOR YOUR SHREDDER

Clean covers with a clean dry cloth. Do not use water or solvents. Make sure you disconnect your shredder from its power source before cleaning.

Paper shredders, like all mechanical equipment, need proper maintenance to ensure efficient operation. Periodic lubrication of the cutting blades is important to offset the friction generated within the cutting head. Frequency of lubrication will vary depending on the shred size and the amount of usage. A strip-cut shredder receiving light use (1 – 2 hours per week) will require lubrication only once or twice a month, while the same machine used 1 – 2 hours per day will require lubrication weekly. A cross-cut shredder should be lubricated every ½ hour of shredding time to maintain maximum capacity and efficiency.

The procedure for lubricating your shredder is simple, and can be performed by any operator. The oil is packaged in a squeeze bottle and is applied directly to the cutting blades through the feed opening (3). Run a fine stream of lubricant from one side of the feed opening to the other. Run the shredder in REVERSE for a few seconds to help distribute the lubricant evenly. You can now continue shredding as usual.

IF ANY OTHER PROBLEMS OCCUR. CALL YOUR AUTHORIZED DAHLE SERVICE DEALER

ALWAYS TURN SHREDDER OFF IF IT WILL BE UNATTENDED FOR LONG PERIODS OF TIME